

Link

USER MANUAL

PowerMouse PowerMouse+

Rev#39



| | | |
|------------|--|-----------|
| 1 | Important Notices and safety information | 4 |
| 1.1 | Limited Warranty | 4 |
| 1.2 | Disposal of Old Electrical & Electronic Equipment | 5 |
| 1.2.1 | Disposal of waste batteries | 5 |
| 1.3 | Declaration of Conformity | 6 |
| 1.3.1 | FCC | 6 |
| 1.3.1.1 | LXNAV AM module | 6 |
| 1.3.1.2 | WiFi module | 7 |
| 1.3.2 | CE | 8 |
| 1 | Revision History | 10 |
| 2 | General overview | 12 |
| 3 | Packing Lists | 13 |
| 3.1 | Part numbers | 13 |
| 4 | Basics | 14 |
| 4.1 | LXNAV PowerMouse and PowerMouse+ at a Glance | 14 |
| 4.1.1 | PowerMouse comparison table | 15 |
| 4.1.2 | LXNAV PowerMouse and PowerMouse+ Features | 15 |
| 4.1.3 | Interfaces | 15 |
| 4.1.4 | Flarm antenna color coding | 16 |
| 4.1.5 | Radio communication | 16 |
| 4.1.6 | Options | 17 |
| 4.1.7 | Technical Data | 17 |
| 4.1.7.1 | Environmental limitations | 18 |
| 4.2 | ADS-B module | 19 |
| 5 | System Description | 20 |
| 5.1 | Switching on the Unit | 20 |
| 5.2 | Normal operation | 20 |
| 5.3 | Bluetooth | 20 |
| 5.4 | Wi-Fi and Bluetooth (PowerMouse+) | 20 |
| 6 | Installation | 21 |
| 6.1 | Connecting LXNAV PowerMouse/PowerMouse+ | 21 |
| 6.2 | Connecting Antennas | 21 |
| 6.3 | USB port | 22 |
| 6.4 | Wiring | 22 |
| 6.4.1 | PowerMouse PORT1 and PORT2 pinout (RJ45) | 22 |
| 6.4.2 | PowerMouse RF connector side description | 23 |
| 6.4.3 | IO cable for PowerMouse+ | 24 |
| 6.5 | Installation examples | 25 |
| 6.5.1 | PowerMouse/PowerMouse+ – FlarmView | 25 |
| 6.5.2 | PowerMouse/PowerMouse+ – FlarmLED | 25 |
| 6.5.3 | PowerMouse/PowerMouse+ – FlarmLED – Oudie | 25 |
| 6.5.4 | PowerMouse/PowerMouse+ – FlarmView – Sxxx Vario | 27 |
| 6.5.5 | PowerMouse/PowerMouse+ – LX9xxx – FlarmView | 27 |
| 7 | Data transfer | 28 |
| 7.1 | Firmware Update | 28 |
| 7.1.1 | Firmware update via USB port (USB stick) | 28 |
| 7.1.2 | ADS-B firmware update via Flash Loader | 28 |
| 7.1.3 | ADS-B firmware update via LXxxxx | 29 |
| 7.2 | Installing a new license | 29 |
| 7.3 | Configuring PowerMouse/PowerMouse+ | 30 |

| | | |
|------------|--|-----------|
| 7.3.1 | Configuring PowerMouse+ via Wi-Fi | 30 |
| 7.3.1.1 | Flight declaration screen | 30 |
| 7.3.1.2 | Flarm settings screen | 30 |
| 7.3.1.3 | Pull down menu | 32 |
| 7.3.2 | FlarmLink Wi-Fi factory reset | 40 |
| 7.3.3 | Configuring PowerMouse settings with PowerFLARM config | 40 |
| 7.3.4 | PowerMouse configuration by using Flarm configuration tool | 42 |
| 7.4 | OGN registration | 45 |
| 7.4.1 | IGC file | 45 |
| 7.4.2 | Flarm CFG file | 45 |
| 7.5 | Saving flight on the USB stick | 46 |
| 7.6 | Updating the obstacle database | 46 |
| 7.7 | Declaring tasks | 48 |
| 8 | Error codes | 49 |
| 9 | PowerMouse/PowerMouse+ Mount | 50 |

1 Important Notices and safety information

Read all safety information before using the device to ensure safe and proper use.

The LXNAV PowerMouse system is designed for VFR use only as an aid to prudent navigation. All information is presented for reference only.

Information in this document is subject to change without notice. LXNAV reserves the right to change or improve their products and to make changes in the content of this material without obligation to notify any person or organization of such changes or improvements.



A Yellow triangle is shown for parts of the manual which should be read carefully and are important for operating the LXNAV PowerMouse system.



Notes with a red triangle describe procedures that are critical and may result in loss of data or any other critical situation.



A bulb icon is shown when a useful hint is provided to the reader.

1.1 Limited Warranty

This LXNAV PowerMouse product is warranted to be free from defects in materials or workmanship for two years from the date of purchase. Within this period, LXNAV will, at its sole option, repair or replace any components that fail in normal use. Such repairs or replacement will be made at no charge to the customer for parts and labor, the customer shall be responsible for any transportation cost. This warranty does not cover failures due to abuse, misuse, accident, or unauthorized alterations or repairs.

THE WARRANTIES AND REMEDIES CONTAINED HEREIN ARE EXCLUSIVE AND IN LIEU OF ALL OTHER WARRANTIES EXPRESSED OR IMPLIED OR STATUTORY, INCLUDING ANY LIABILITY ARISING UNDER ANY WARRANTY OF MERCHANTABILITY OR FITNESS FOR A PARTICULAR PURPOSE, STATUTORY OR OTHERWISE. THIS WARRANTY GIVES YOU SPECIFIC LEGAL RIGHTS, WHICH MAY VARY FROM STATE TO STATE.

IN NO EVENT SHALL LXNAV BE LIABLE FOR ANY INCIDENTAL, SPECIAL, INDIRECT OR CONSEQUENTIAL DAMAGES, WHETHER RESULTING FROM THE USE, MISUSE, OR INABILITY TO USE THIS PRODUCT OR FROM DEFECTS IN THE PRODUCT. Some states do not allow the exclusion of incidental or consequential damages, so the above limitations may not apply to you. LXNAV retains the exclusive right to repair or replace the unit or software, or to offer a full refund of the purchase price, at its sole discretion. SUCH REMEDY SHALL BE YOUR SOLE AND EXCLUSIVE REMEDY FOR ANY BREACH OF WARRANTY.

To obtain warranty service, contact your local LXNAV dealer or contact LXNAV directly.

1.2 Disposal of Old Electrical & Electronic Equipment

(Applicable in the European Union and other European countries with separate collection systems)



This symbol on the product or on its packaging indicates that this product shall not be treated as household waste. Instead it shall be handed over to the applicable collection point for the recycling of electrical and electronic equipment. By ensuring this product is disposed of correctly, you will help prevent potential negative consequences for the environment and human health, which could otherwise be caused by inappropriate waste handling of this product. The recycling of materials will be a help to conserve natural resources. For more detailed information about recycling of this product, please contact your local Civic Office, your household waste disposal service, or the shop where you purchased the product.

1.2.1 Disposal of waste batteries

(Applicable in the European Union and other European countries with separate collection systems)



This symbol on the battery or on the packaging, indicates that the battery provided with this product shall not be treated as household waste. By ensuring these batteries are disposed of correctly, you will help prevent potentially negative consequences for the environment and human health, which could otherwise be caused by inappropriate waste handling of the battery. The recycling of the materials will help to conserve natural resources. In case of products that for safety, performance or data integrity reasons, require a permanent connection with an incorporated battery, this battery should be replaced by a qualified service staff only. To ensure that the battery will be treated properly, hand over the product at end-of-life to the applicable collection point for the recycling of electrical and electronic equipment. For all other batteries, please view the section on how to remove the battery from the product safely. Hand the battery over to the applicable collection point for the recycling of waste batteries. For more detailed information about recycling of this product or battery, please contact your local Civic Office, your household waste disposal service or the shop where you purchased the product.

(Applicable for Customers in the U.S.A. and Canada)

Lithium-Ion batteries are recyclable. You can help preserve our environment by returning your used rechargeable batteries to the collection and recycling location nearest you. For more information regarding recycling of rechargeable batteries, call toll free 1-800-822-8837, or visit <http://www.rbrc.org/>



1.3 Declaration of Conformity



1.3.1 FCC

1.3.1.1 LXNAV AM module

| | |
|------------------------|--|
| Product: | Flarm receiver with GPS |
| Type reference: | PowerMouse+ |
| Manufacturer: | LXNAV d.o.o., Kidričeva 24, 3000 Celje, Slovenia |
| Trademark: | LXNAV |
| FCC ID: | 2ASPHLXNAVAM |
| Operating frequencies: | 902.4MHz-927.8MHz |
| Ratings: | 8-36VDC |
| | Protection class: III |
| Testing Method: | 47 CFR Part 15, Subpart B (Clause 15.107 and 15.109) |

This device complies with Part 15 of the FCC.

Operation is subject to the following two conditions:

- (1) this device may not cause harmful interference, and
- (2) this device must accept any interference received, including interference that may cause undesired operation.

The following test reports are subject to this declaration:

Test report number: T251-0588/19 Issue date:8.8.2019

Within the USA, the device may only be used in transportation vehicles such as aircraft or motor vehicles.

The following importer is responsible for this declaration:

Company name: _____
 Company address: _____
 Telephone: _____

1.3.1.2 WiFi module

Product: WiFi module
Type reference: PowerMouse+
Manufacturer: ESPRESSIF SYSTEMS (SHANGHAI)
CO., LTD
Trademark: ESPRESSIF SYSTEMS
FCC ID: 2AC7Z-ESPS3WROOM1
Operating frequencies: 2402.0MHz-2480.0MHz 2412.0MHz-2462.0MHz

This device complies with Part 15 of the FCC.

Operation is subject to the following two conditions:

- (1) this device may not cause harmful interference, and
- (2) this device must accept any interference received, including interference that may cause undesired operation.

The following test reports are subject to this declaration:

The following importer is responsible for this declaration:

Company name: _____
Company address: _____
Telephone: _____

1.3.2 CE***Declaration of conformity***

Hereby, LXNAV d.o.o. declares under its sole responsibility that the following product is compliant with the essential requirements and other relevant provisions of the Radio Equipment Directive (RED) 2014/53/EU

Identification of product

Power Mouse and Power Mouse+
Type: IGC and Non IGC

Manufacturer

LXNAV d.o.o.
Kidričeva ulica 24,3000 Celje, Slovenija

Related standards

RED directive 2014/53/EU

Remark

The product is designed to comply with LXNAV standards and standards harmonised with directive 2014/53/EU:

| | |
|--------|--|
| Safety | EN 62368-1:2014+A11:2017 EN 62368-1:2014 |
| Health | EN 62479:2010 EN 50665:2017 |
| EMC | EN 301 489-1 V2.1.1 EN 301 489-19 V2.1.1 (2019-4) EN 301 489-1 V2.2.3 (2019-11) EN 301 489-3 V2.3.2 (2023-01) EN 301 489-17 V3.1.1 EN 301 489-17 V3.2.4 |
| Radio | EN 300 328 V2.2.2 EN 303 413 V1.2.1 (2021-4) EN 300 220-1 V3.1.1 (2017-02) EN 300 220-2 V3.2.1 (2018-06) |

Celje, 20.03.2023

Authorized signature
Erazem Polutnik, CEO

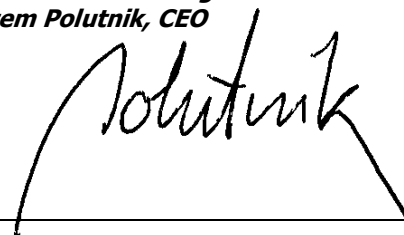

1 Revision History

| Date | Revision | Revised by | Description |
|----------------|----------|------------|---|
| November 2017 | 1 | | Initial release of this manual |
| January 2017 | 2 | | New chapter 3 |
| February 2018 | 3 | | Flarm Tools removed from manual |
| March 2018 | 4 | | Added chapter 5.3, Updated chapter 0 |
| April 2018 | 5 | | Added chapters 6.2, 0 |
| April 2018 | 6 | | Added chapters 6.3, 6.4.2 |
| July 2018 | 7 | | Added chapters: 6.2, Updated chapter: 4.3, 5.4.1.1, 6.4 |
| October 2018 | 8 | | Updated chapters: 0, 6.4, Added chapters: 7.1.3 |
| December 2018 | 9 | | Swapped naming of port1 and port2 in Ch:6.4.1, 7.1.2 |
| January 2019 | 10 | | Updated packing list |
| February 2019 | 11 | | Updated chapter: 6.4 |
| March 2019 | 12 | | Updated chapter: 7.6 |
| June 2019 | 13 | | Added chapter:7.1.3 |
| August 2019 | 14 | | Added chapters:1.3.1, Napaka! Vira |
| September 2019 | 15 | | Updated chapter: 7.3.1 |
| October 2019 | 16 | | Updated chapters: 7.1.1,7.1.2,7.1.3 |
| November 2019 | 17 | | Updated chapters: 6.1.1 |
| April 2020 | 18 | | Updated chapters: 6.1.1 |
| June 2020 | 19 | | Added Chapter 0 |
| July 2020 | 20 | | Added Chapter 6.5 |
| July 2020 | 21 | | Updated Chapter 6.2 |
| December 2020 | 22 | | Added Chapter 7.4 |
| March 2021 | 23 | | Updated Ch. 7.6 |
| May 2021 | 24 | | Style update, minor fixes |
| July 2021 | 25 | UK | Added chapter 8, minor fixes |
| September 2021 | 26 | UK | Added chapters: 2, Updated chapters: 6.2,7.4.2 |
| July 2022 | 27 | UK | Updated Ch. 4.1.7 |
| November 2022 | 30 | UK | Updated chapters 1,1.3,1.3.2 |
| December 2022 | 31 | UK | Added Ch. 4.5.1., 7.2, Updated Ch. 7.3.1 |
| March 2023 | 32 | UK | Updated Ch. 1.3.2 |
| June 2023 | 33 | UK | Added Ch. 4.5.1. |
| February 2024 | 34 | UK | Updated ch. 4.1.3,5.3 |
| March 2024 | 35 | UK | Added chapter: 0, PowerMouse+ Chapter 7.3.1 and subchapters |
| April 2024 | 36 | UK | Updated ch.4.1.1 |
| May 2024 | 37 | UK | Updated ch.4.1.7, 4.2, 4.1.3, 6.3, 6.27.1 |
| June 2024 | 38 | UK | Added ch. 7.3.3 |
| July 2024 | 39 | UK | Updated ch.5.3, added 7.3.2 |

2 General overview

FLARM is the collision avoidance system and traffic awareness/electronic conspicuity technology used by General Aviation, light aircraft, and UAVs. It has been designed to support self-separation for both VFR and IFR in applicable airspace classes. Aircraft with a FLARM system alert the pilots when on a collision course with another aircraft. Similar to TCAS/TAS, visual and aural warnings indicate that a collision is imminent, requiring the pilots to take action. However, unlike TCAS, FLARM does not issue Resolution Advisories (RA), so pilots need to select the appropriate course of action themselves.

FLARM works by calculating and broadcasting its own predicted future 3D flight path to nearby aircraft. At the same time, it receives the future flight path from surrounding aircraft. An intelligent motion prediction algorithm calculates a collision risk for each aircraft based on an integrated risk model.

The system determines its position, altitude, and movement with a sensitive GNSS/GPS receiver. Based on those and other parameters, a precise projected flight path can be calculated. The flight path, together with additional information such as an identification number, is encoded before being broadcast over an encrypted radio channel twice per second. Flight models are available for most aircraft types, including piston-engine airplanes, jets, helicopters, gliders, hang gliders, paragliders, UAVs, etc.

PowerMouse also incorporates an ADS-B and transponder (SSR) Mode-S receiver. This enables aircraft that are not yet equipped with FLARM to also be detected and included in the collision prediction algorithm.

FLARM was invented in 2004 following an increasing number of mid-air collisions. Research and accident investigations had shown that the see-and-avoid principle was insufficient to reliably detect approaching aircraft in time. It initially spread in the domain of non-powered aircraft but was soon followed by rapid expansion in powered airplanes and helicopters. Over 50,000 manned aircraft and many more UAVs already have a FLARM-system installed. In Europe, more than 50% of all General Aviation aircraft have FLARM (including nearly 100% of gliders). The technology has additionally spread to other parts of the world and is today also used most prominently in North and South America, Australia, New Zealand, South Africa, Israel, and some Asian countries.

In addition to annunciating collision warnings, many FLARM systems can also show nearby aircraft on a radar-like screen (CDTI). Similar to the use of weather radar to avoid thunderstorms, this can be helpful for short to medium term strategic planning in high traffic density situations.

FLARM can also warn about fixed obstacles like masts and power lines. Obstacle collision warnings are based on an optionally installed database, which needs to be kept up to date.

FLARM systems are available from many different manufacturers under different product names. A system normally consists of a remotely installed FLARM device, a panel-mounted FLARM Compatible display, one or two externally mounted FLARM antennas, and internally mounted GNSS and ADS-B/SSR antennas. There are also portable FLARM devices available (usually with an integrated display), as well as FLARM systems integrated into other avionics (e.g. EFIS-systems).

FLARM is approved by EASA and others for installation in certified aircraft and is recommended by many aviation authorities and organizations. The installation is normally a minor change and can be done by any competent maintenance organization. Several General Aviation airports have started requiring FLARM for all aircraft. FLARM is also mandatory in France for gliders and a similar requirement for light powered aircraft is under investigation.

3 Packing Lists

PowerMouse

- T-dipole FlarmAntenna
- Bluetooth Antenna
- GPS antenna
- 2nd Dipole FlarmAntenna is optional
- USB stick
- Flarm power supply cable
- FlarmView/FlarmLED (Optional)

PowerMouse+

- T-dipole FlarmAntenna
- Wi-Fi Antenna – FCC version has integrated Wi-Fi antenna
- GPS antenna
- 2nd Dipole FlarmAntenna is optional
- ADSB Antenna is optional
- USB stick
- Flarm power supply cable
- IO cable (Button and Audio output)
- FlarmView/FlarmLED (Optional)

3.1 Part numbers

| Model | Part number | Description |
|----------------------|-----------------------|--|
| PowerMouse | <u>PowerMouse</u> | PowerMouse with built-in Bluetooth module, Gps antenna, Bluetooth antenna, 1x Dipole antenna included |
| PowerMouse+ | <u>PowerMouse +</u> | PowerMouse+ with RFB (second receiver), built-in Wi-fi,Bluetooth module, GPS antenna, Bluetooth antenna, 2x Dipole antenna included, ADS-B receiver, 1x short90° dipole antenna |
| PowerMouse+GA | <u>PowerMouse +GA</u> | PowerMouse+ for General Aviation with RFB (second receiver), built-in Bluetooth module, GPS antenna, Bluetooth antenna, 2x Dipole antenna included, ADS-B receiver, 1x short90° dipole antenna |

4 Basics

4.1 LXNAV PowerMouse and PowerMouse+ at a Glance

PowerMouse (both versions) is a standalone PowerFlarm® with external GPS antenna, USB socket, internal Bluetooth module and Wi-Fi module which is available in PowerMouse+.

It's a collision avoidance device, designed for gliders as well as for other participants in the air. FLARM® is in widespread use and features include:

- Display of nearby Flarm traffic with warning visually and acoustically of approaching other aircraft or fixed obstacles (where database has been installed)
- intelligent motion prediction which minimizes nuisance alarms and supports situational awareness
- integration with over 50 compatible products by other manufacturers (e.g. PDA moving maps) through open serial port protocol
- USB socket for easy uploads and downloads, IGC-format flight recording and OLC-approval
- based on award-winning original FLARM® design, endorsed by FAI, IGC/OSTIV and EASA (AMC Part 21, Part M)
- optional diamond-level IGC-approval with/without engine noise sensor (ENL)
- a typical radio range that can be verified with online radio range analyzer
- powerful 72-channel high-precision uBlox NEO8-GPS module
- full compatibility with wide range of Flarm-licensed products
- operation on a license-free radio band, not based on transponder technology
- small size and simple installation

PowerMouse is available in 5 variants:

- PowerMouse with Flight recorder (Not approved by IGC), with enabled SAR (search and rescue) function
- PowerMouse with IGC approved Flight recorder (Up to Diamonds) and SAR function
- PowerMouse with IGC approved Flight recorder (Up to Diamonds), Engine noise sensor and SAR function
- RFB – second Flarm antenna (dual antenna diversity) -available for all versions (Non IGC, IGC and IGC ENL)
- ADS-B module as an option



Not approved Power mouse will arrive with non-valid IGC number. When purchasing IGC approved Flight recorder option you will receive instructions from LXNAV on how to make your Power Mouse IGC approved. New IGC number will be allocated after the procedure is done.

4.1.1 PowerMouse comparison table

| Options | PowerMouse | PowerMouse+ | PowerMouse+ GA |
|-----------------------------------|------------------------------|-------------------|-------------------|
| RFB | Yes | Yes | Yes |
| USB | Yes | Yes | Yes |
| Bluetooth | Yes (not for the US market) | Yes | Yes |
| Wi-Fi | | Yes | Yes |
| TCPIP | | Yes | Yes |
| Configurable Audio output | | Yes | Yes |
| External configurable push button | | Yes | Yes |
| IGC option | Optional | Yes | No |
| ENL option | Optional | Yes | No |
| FCC approval | Yes (PowerMouse FCC version) | Yes (FCC version) | Yes (FCC version) |

4.1.2 LXNAV PowerMouse and PowerMouse+ Features

- USB stick socket for configuration of Flarm, firmware update or storing IGC flights
- IGC flight recorder (Up to Diamond level)
- Optionally preloaded obstacles (where databases are available) – Obstacles are not free of charge.
- Expandable to all standard Flarm displays
- Designed for FlarmView
- Low current consumption
- Second Flarm antenna (included in PowerMouse+)
- ADSB input (included in PowerMouse+)
- Wi-Fi integrated (only at PowerMouse+)
- IGC flight recorder (optionally at PowerMouse and included in the PowerMouse+)
- ENL option (optionally at PowerMouse and included in the PowerMouse+)

4.1.3 Interfaces

PowerMouse

- Two Standard Flarm/IGC port on RJ45 with serial RS232 interface
- USB Port (up to 2.0)
- Bluetooth (Not available in US version)
- 2xSMA for Flarm antenna (US version has reverse polarity SMA)
- 1xSMA for ADSB antenna

PowerMouse+

- Two Standard Flarm/IGC port on RJ45 with serial RS232 interface
- USB Port (up to 2.0)
- Wi-Fi/Bluetooth
- 2xSMA for Flarm antenna (US version has reverse polarity SMA)
- 1xSMA for ADSB antenna
- Audio output
- Digital input



Default baud rate of PowerMouse is set to 19200bps. In case, that you have any problems with Flarm indicator (FlarmView), please check baud rate setting on it.



Due to new Bluetooth module baud rate of PowerMouse from serial number **01823** must be set to 115200bps. In case, that you have any problems with Flarm indicator (FlarmView), please check baud rate setting on it.

4.1.4 Flarm antenna color coding

The flarm antennas should be designed and tuned for the frequency band applicable to the geographic area, where the aircraft is being operated. If not specified, by default is supplied antenna for Europe Red marked.

Red marked antenna is for Europe (868.2Mhz)

Blue marked antenna is for USA, CANADA, Australia (915MHz)

Green marked antenna is for USA with **reverse polarity SMA** (915MHz) – FCC approved

| Options | PowerMouse | PowerMouse+ | PowerMouse+ GA |
|---------|------------|-------------|----------------|
| RFB | Yes | Yes | Yes |
| USB | Yes | Yes | Yes |



Power Mouse cannot detect the type of the Flarm Antenna.



FCC approved PowerMouses has reverse polarity connector. Be careful, if you are migrating from EU PowerMouse to US PowerMouse, to us the appropriate Flarm Antenna!

For better coverage a user can choose between Powermouse with or without flarm antenna. PowerMouse with two flarm antennas has better coverage. It is strongly recommended to use diversity flarm antenna on aircraft, which contains a lot of metal parts.

- Antennas must be installed vertically
- Antennas should be installed at least 30cm apart, including other antennas. Like COM/NAV, XPDR,...
- ADSB antenna must be mounted vertically

4.1.5 Radio communication

Power Mouse operates on SRD860 band (≈ 868 MHz – EU, NZ) or an ISM band (≈ 915 MHz - NA) in different parts of the world. Power Mouse automatically changes the frequency based to GPS position.

| Area | Frequency |
|---------------|------------------|
| Africa | 868.2 – 868.4MHz |
| Australia | 917.0 – 926.6MHz |
| Europe | 868.2 – 868.4MHz |
| Israel | 916.2MHz |
| New Zealand | 869.2MHz |
| North America | 902.2-927.8MHz |
| South America | 917.0-926.2MHz |

4.1.6 Options

One or more external Flarm Displays can be connected (FlarmView/FlarmLED)

4.1.7 Technical Data

PowerMouse

- Power input 8-36 V DC
- Consumption 1.02W (85mA @12V) excl. power for USB stick
- Weight 160 g
- 55mm x 90mm x 25mm
- Operating temperature -30°C to +60°C (-22°F to +140°F)
- Storage temperature -40°C to +80°C (-40°F to +176°F)
- Communication frequency: SRD860 band (\approx 868 MHz – EU, NZ) or an ISM band (\approx 915 MHz - NA) in different parts of the world
- Maximum radiated transmission power: (EU)14dBm (NA):17dBm
- Bluetooth 4.0 LE (not available with FCC version)
- BLE antenna gain 6dBi
- Flarm antenna gain 3dBi
- USB connection for 2.0 flash drive (FAT16, FAT32 or exFAT, 128GBytes max.)

PowerMouse+

- Power input 8-36 V DC
- Consumption 2.22W (185mA @12V) excl. power for USB stick
- Weight 160 g
- 55mm x 90mm x 25mm
- Operating temperature -30°C to +60°C (-22°F to +140°F)
- Storage temperature -40°C to +80°C (-40°F to +176°F)
- Communication frequency: SRD860 band (\approx 868 MHz – EU, NZ) or an ISM band (\approx 915 MHz - NA) in different parts of the world,
- Maximum radiated transmission power: (EU)14dBm (NA):17dBm
- Wireless data: Wi-Fi (TCP, Web socket) and BT4LE on band 2.4GHz
- Wi-Fi antenna gain 6dBi, FCC version has integrated Wi-Fi antenna
- Flarm antenna gain 3dBi
- USB connection for 2.0 flash drive (FAT16, FAT32 or exFAT, 128GBytes max.)
- Audio (Max output 2.1 Vpp, output impedance 600Ohm)

4.1.7.1 Environmental limitations

- Operating temperature: -20°C to +70°C
- Storage temperature: -30°C to +85°C
- Relative humidity: 0%-95%
- Vibration: +/- 50m/s² at 500Hz

4.2 ADS-B module

PowerMouse device has a possibility to have an internal ADSB module, which is the ADSB IN module. All four variants can have the ADSB.

ADSB module is not a standard part of the PowerMouse, therefore when ordering you have to order PowerMouse with ADSB.

ADSB can receive MODE S transponders with ADSB OUT. You will see all traffic equipped with mode S transponders.



ADSB module can be retrofitted into PowerMouse units without it (except for serial numbers from 1-100).

5 System Description

5.1 Switching on the Unit

Unit is switched on automatically, when it gets valid power supply from either PORT1 or PORT2 RJ45 connector.

5.2 Normal operation

PowerMouse goes into normal operating mode, when it receives signals from enough GPS satellites. Then the device becomes visible to and receives data from other FLARM devices.

5.3 Bluetooth

To connect to the PowerMouse via Bluetooth, you must search on a PDA/Smartphone for Bluetooth enabled devices in range. Click PAIR or CONNECT to connect to the PowerMouse. Device will appear as LXNAV-FPM-(5-digit serial). Device doesn't require any pairing password.

Bluetooth is always ON and cannot be configured. Purpose of Bluetooth is to send Flarm objects to the other Bluetooth device. When device is on Bluetooth LED will flash blue every 3 seconds, when device is successfully connected in will flash twice every second.



Due to new Bluetooth module baud rate of PowerMouse from serial number **01823** must be set to 115200bps to have Bluetooth operating normally. PowerMouses below that serial number must have set the baudrate to 19200 to receive the data stream via Bluetooth module.



FCC version of PowerMouse has no Bluetooth module. PowerMouse+ has WiFi and Bluetooth.

5.4 Wi-Fi and Bluetooth (PowerMouse+)

Please scan the QR code on the PowerMouse+. Your smart phone will connect automatically to the PowerMouse+ access point. Via a web browser you can configure all PowerMouse+ settings.

Bluetooth interface can be as well enabled here.

Until a Wi-Fi connection is established, a Bluetooth connection is not possible. Likewise, if the Bluetooth connection is established, the Wi-Fi connection will not work

6 Installation

PowerMouse can be installed behind the instrument panel.

6.1 Connecting LXNAV PowerMouse/PowerMouse+

LXNAV PowerMouse is connected to DC power supply using PF POWER 12 VDC cable. Red wire goes to + positive and blue wire goes to – ground. External indicator can be connected via a splitter or directly to the other port.



Instrument has no internal fuse. **3A external fuse is required!**

6.2 Connecting Antennas

PowerMouse has 4 connectors for different antennas. Two SMA connectors (A and B) are for FLARM Antennas and there is one antenna for the ADSB (optionally). GPS connector serves for GPS antenna and BT connector for Bluetooth antenna.



Following FLARM Antennas are available:

- Short Dipole (90°) $\lambda/4$
- Long dipole (90°) $\lambda/2$
- Flat folded dipole
- Classic dipole
- Antenna with ground plate
- T-Dipole antenna (default option)



For better range, FLARM antennas must be positioned vertically, away from metal/carbon parts and cables, with clear view to the sky.



For additional information about installation of antennas you may have a look at FLARM's official application note:

<https://flarm.com/wp-content/uploads/man/FTD-041-Application-Note-FLARM-Antenna-Installation.pdf>



1x Flarm T-dipole antenna is included in the package. When you buy RFB option, the second antenna is included as well.

6.3 USB port

USB port serves as a SD card on other Flarm devices (FlarmMouse). Advantage of the USB is, that you can install PowerMouse behind the panel and connect USB extension cable to the front panel.

User can use it for:

- Updating PowerMouse
- Changing PowerMouse settings (flarmcfg.txt)
- Downloading flights



With PowerMouse+ the USB port can be used for IO cable connection.



USB is active only when the device is powered ON.

It supports up to USB 2.0 type



The maximum supported size of the USB memory stick is 128GBytes

6.4 Wiring

6.4.1 PowerMouse PORT1 and PORT2 pinout (RJ45)

RJ45 socket is complies with IGC GNSS FR specification, except pin 3.

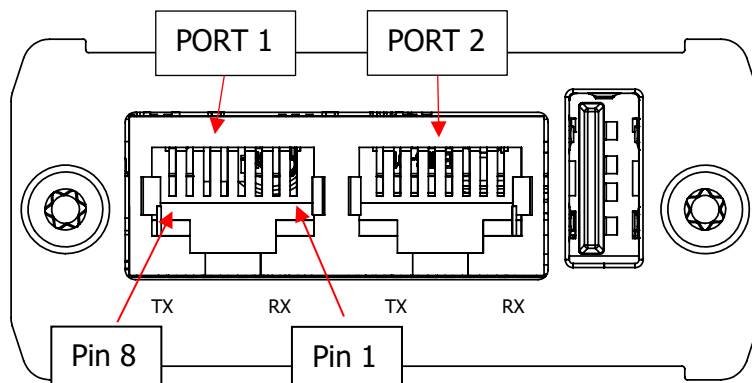

| Pin number | Description |
|------------|-----------------------------|
| 1 | + Power input |
| 2 | + Power input |
| 3 | 3.0V Indicator power output |
| 4 | Ground |
| 5 | Data output (TX) |
| 6 | Data input (RX) |
| 7 | - Power input |
| 8 | - Power input |



The pinout numbering is by internal standard.



Connecting power supply to wrong pin may burn an internal circuit board!



Underneath each port there are TX (transmit-green) and RX (receive-red) status LEDs that flash when that port is receiving or transmitting data.

6.4.2 PowerMouse RF connector side description

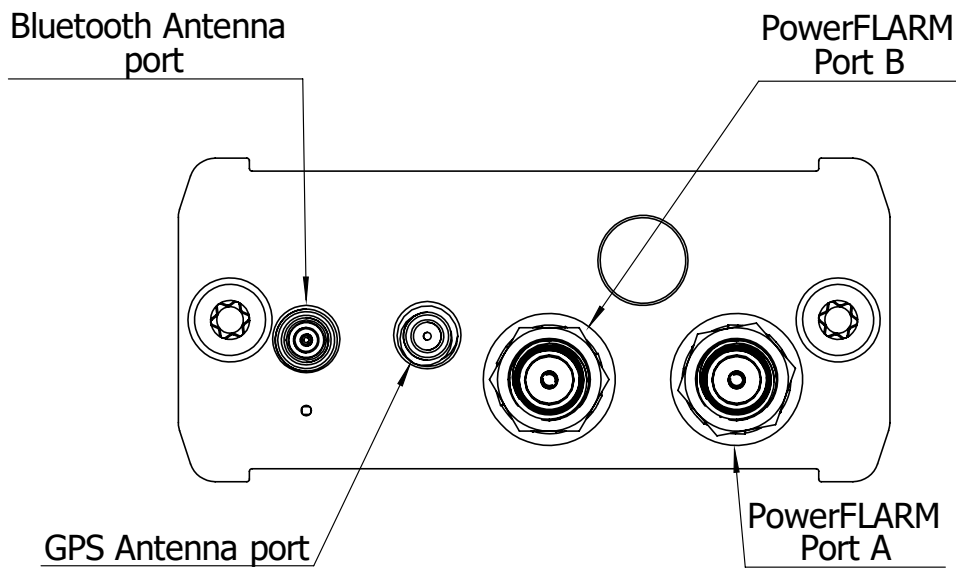

Bluetooth Antenna is not available on the PowerMouse FCC and PowerMouse+ FCC. PowerMouse+FCC has integrated Wifi/Bluetooth antenna

PowerMouse

| Connector description | Connector type |
|------------------------|----------------|
| Bluetooth Antenna port | MCX |
| GPS Antenna port | SMC |
| PowerFLARM Port A | SMA |
| PowerFLARM Port B | SMA |
| ADSB | SMA |

PowerMouse+

| Connector description | Connector type |
|------------------------------|-----------------------|
| GPS Antenna port | SMC |
| PowerFLARM Port A | SMA-RP |
| PowerFLARM Port B | SMA-RP |
| ADSB | SMA |

In the line with ADSB antenna connector is red LED, which blinks, when ADSB traffic is present. Below BT antenna connector is blue LED, which indicates BT activity.

6.4.3 IO cable for PowerMouse+

PowerMouse+ has an additional cable with audio output and one digital input. Audio output can be connected for example to an audio panel of the powered plane. Via Wi-Fi interface user can configure audio messages and alerts. More about audio settings you can read in a chapter. 7.3.1.3.12. The audio connector is a classic 3.5mm mono phono jack.

Digital input can be configured as well. The digital can recognize click (short press) or long press of the button. The user can configure the action for a short and long press. More about the configuration of the input you can read in a chapter. 7.3.1.3.13. Digital input is prepared as open lead wires.

6.5 Installation examples

6.5.1 PowerMouse/PowerMouse+ – FlarmView

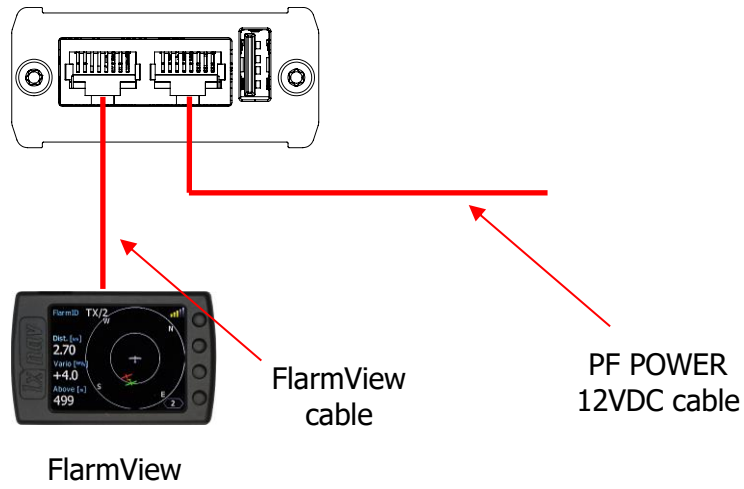

6.5.2 PowerMouse/PowerMouse+ – FlarmLED

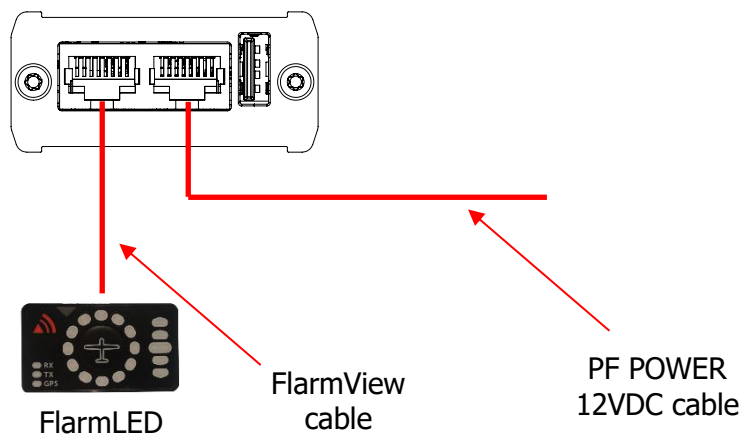

6.5.3 PowerMouse/PowerMouse+ – FlarmLED – Oudie

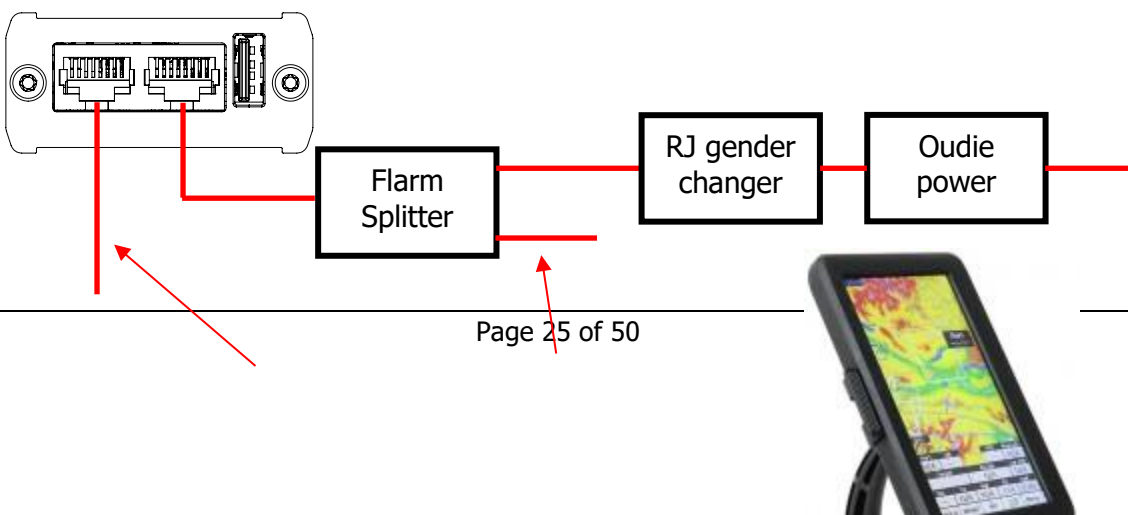



FlarmLED

FlarmView
cable

PF POWER
12VDC cable

OU DIE



6.5.4 PowerMouse/PowerMouse+ – FlarmView – Sxxx Vario

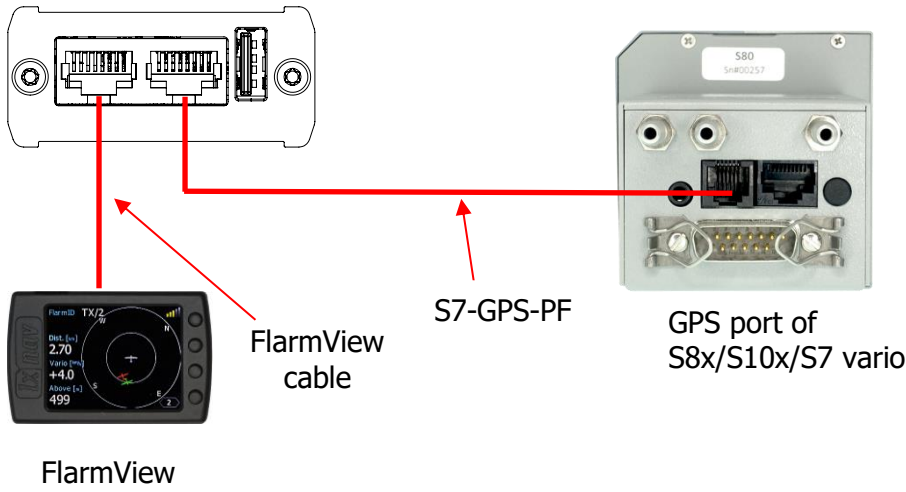

6.5.5 PowerMouse/PowerMouse+ – LX9xxx – FlarmView

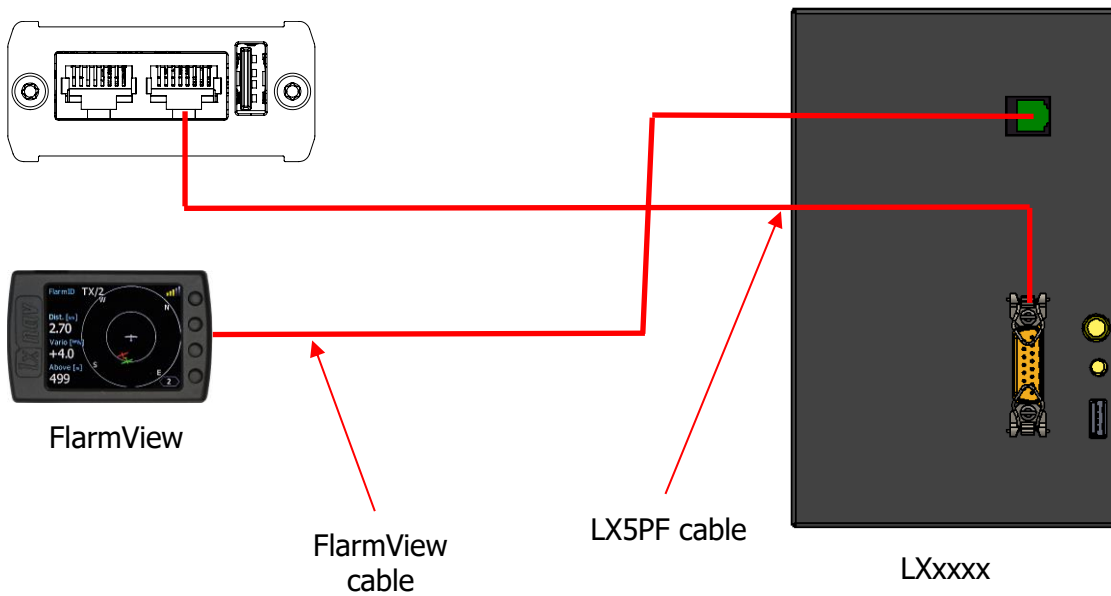

7 Data transfer

7.1 Firmware Update

PowerMouse has three separate firmwares:

- PowerFlarm firmware (See Ch. 7.1.1)
- ADSB firmware (See Ch. 7.1.2)
- FlarmLink firmware (See Ch.7.3.1.3.8)

7.1.1 Firmware update via USB port (USB stick)

This Method is the easiest one and therefore preferred. The firmware update will be executed, when the system finds the file named `pf_am_x.xx_*.fw` (x= version nr.) on the USB stick root. This file can be downloaded at <https://gliding.lxnav.com/lxdownloads/firmware/>.

Update procedure:

- Switch off the Flarm and insert the USB stick.
- Now switch on the device
- The procedure will start automatically, it takes about one minute.
- When ready, switch off the Flarm
- Please delete the firmware file from the USB stick after the update



It is recommended to have only one copy firmware file on USB stick. More fw files will make problems and unwanted firmware updates...

If you plug in an empty USB stick, some files will copy on it some files (all igc files and NGAx.txt (x = internal Flarm SN))



In this file you can find a description about firmware

```
00008.783 INFO   PowerFLARM firmware: 7.0
00008.786 INFO   Build: 0124db65d, Date: 2020-03-04T09:06:14
00008.786 INFO   Expiration date (hard): 01.11.2021, soft: 02.10.2021
```



If you are using graphics Flarm display you can read there the information about Flarm

7.1.2 ADS-B firmware update via Flash Loader

This method is used if you wish to update an ADS-B module in PowerMouse.

You can get flash loader at: <https://gliding.lxnav.com/lxdownloads/firmware/> (S7 PC update tool).

For the update you need file named `_x*.lxfw` (x= version nr.) on your computer.

Update procedure:

- Switch off the Flarm and connect it to your PC via Port 2 on PowerMouse.
- Select communication port to which your PowerMouse is connected to
- Select baudrate 57600
- Select root direction of your .lxfw file
- Press Flash
- Turn the device back on

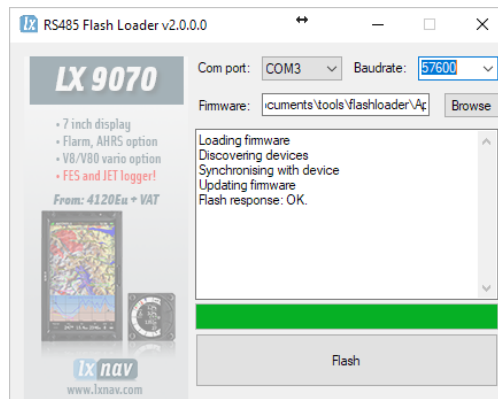

To update ADS-B module, a cable **Flarm update 12V DC** is required and a Comm port on PC.

7.1.3 ADS-B firmware update via LXxxxx

If Power mouse is connected to LXxxxx via LX5PF or LX5Flarm cable connected to Port 2 on PowerMouse, firmware update can be performed directly from LXxxxx. Load an update file to SD card and put SD card into LXxxxx device. If LXxxxx has no built in Flarm, just enter password 89891 and select file with ADSB firmware **App_FADS_X.XX.ixfw**.

In case you have built in Flarm and connected external PowerMouse, before update procedure described above, enter password 49147.

7.2 Installing a new license

If you need to activate a purchased license (example ENL), you must do that via USB. Copy the received license file (.lic) to your USB drive. Insert the USB in to powered down Power mouse and then power on the device. The license will install automatically.

7.3 Configuring PowerMouse/PowerMouse+



Traffic data will be present only if baud rate is set to 19200 or higher.

7.3.1 Configuring PowerMouse+ via Wi-Fi

Wi-Fi connection between PowerMouse+ and smart phone can be established simply with scanning the QR code on the PowerMouse+ housing or manually. The password for PowerMouse+ Wi-Fi access point is as well on the label near the QR code. If the main flight declaration screen will not appear automatically in a browser, you can open a browser and enter **192.168.1.1**



PowerMouse (not plus version) can be configured the same way by using FlarmLink dongle.

7.3.1.1 Flight declaration screen

On this screen user can enter the pilot's and glider information.

The screenshot shows the 'FLIGHT DECLARATION' screen in the 'ix nav' application. The top bar contains the 'ix nav' logo, a location icon, a settings gear icon, and a menu icon. The main content area has the following fields:

- Pilot:** A text input field containing the name 'Lordi'.
- Copilot:** A text input field containing the value 'undefined'.
- Glider type:** A dropdown menu with 'Cirrus VTC' selected and a downward arrow.
- Registration:** A text input field containing the registration number 'D-7127'.

7.3.1.2 Flarm settings screen

Can be entered by pressing to the top status bar a setting icon.



FLARM SETTINGS

Device type

PowerMouse

Current port

Port 1

Distance unit

Meters

Altitude unit

Meters

7.3.1.3 Pull down menu

The following list of pages will appear on the pull-down menu.

- FlarmStatus
- CarpRange analyzer
- Traffic monitor
- Logbook
- FlarmUpload License file
- FlarmUpload Obstacle file
- FlarmUpload firmware
- FlarmLink information
- FlarmLink Wi-Fi setup
- FlarmLink Bluetooth setup
- FlarmLink database update
- FlarmLink sound settings
- FlarmLink Button settings



7.3.1.3.1 FlarmStatus

On that screen you can see the status of the GPS, flarm and ADSB receiver. Information about the Flarm and ADSB firm wares, loaded obstacle databases,...

| | |
|---|---|
| <p>ADSB INFO</p> <p>Hardware: 1 Firmware: 1.41 SN: 666 FPGA Ver: 8 AdsbRxOk: 4 AdsbRx: 0</p> <p>NMEA STREAM</p> <pre> 8.0.0.0*49 SPLXVC.A.AGC.34.595*68 SPFLAU.0.1.1.1.0.0...*63 SPGRMZ.007.F.2*35 SGPRMC.133707.00,A,4614.89156,N,01516.62451,E,0.042,120324,A,Y*00 SGPGGA.133707.00,4614.89156,N,01516.62451,E,1.09,0.95,278.A,M,42.2,M,*5E SGPGSA.A,3,25,28,31,24,27,18,23,05,29,...,1,63,0.95,1,32,1*1F SPLXVI.1.610.0.0*49 SPLXVC.A.AGC.34.595*68 SPFLAU.0.1.1.1.0.0...*63 SPGRMZ.010.F.2*33 </pre> | <p>FLARM STATUS</p> <p>GPS status: 3D Latitude: N 46.234861 Longitude: E 15.277074 GPS altitude: 320 m Number of satellites: 9 Tx: Transmission Rx: 0 Pressure altitude: 245 m</p> <p>FLARM INFO</p> <p>SW version: 7.21 HW version: 1.1 IGC version: EmptyPlaceholderObst</p> |
|---|---|

7.3.1.3.2 Carp Range

Carp range will show us the receiving performance of our flarm device for each antenna separately.

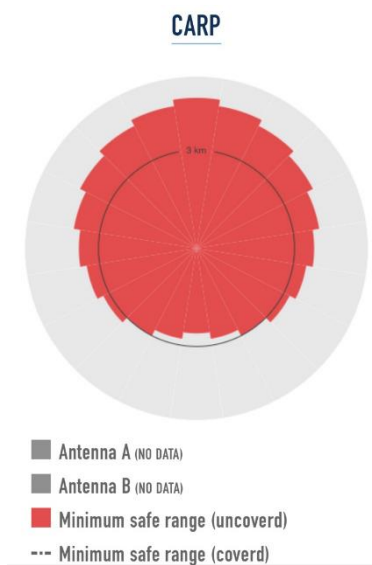

7.3.1.3.3 Traffic monitor

Here we can observe live flarm and ADSB traffic. By each target is possible to show labels for FlarmID, competition ID and its vertical distance.

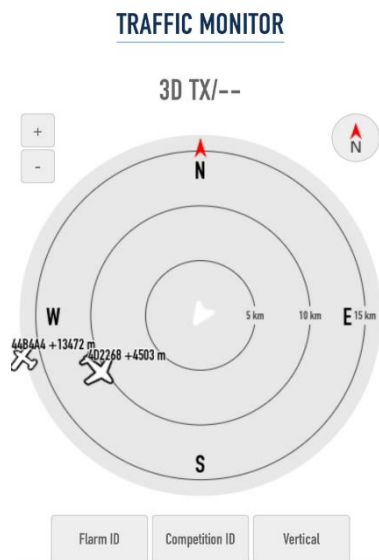

7.3.1.3.4 Logbook

If the flarm has flight recorder capability, you can download the flights here. Flights are in IGC file format.

7.3.1.3.5 FlarmUpload License file

This menu is useful only if the customer wants to activate one of available flarm licenses, that are not active yet (eg. ENL license).

7.3.1.3.6 FlarmUpload Obstacle file

Flarm obstacle database can be loaded here.

7.3.1.3.7 FlarmUpload firmware

Flarm firmware can be laded here. Be sure, you have downloaded first the firmware form our web site, section downloads/firmware.

7.3.1.3.8 FlarmLink information

FlarmLink info is the information about FLarmLink interface (Wi-Fi). For further improvements, it can be updated here.

FLARM LINK INFO

Serial number: 666
Hardware version: 1
Software version: 1.00

FLARM LINK UPDATE

Update file

No files selected

Step 1

BROWSE

Step 2

7.3.1.3.9 FlarmLink Wi-Fi setup

On this page user can change the Wi-Fi password and Wi-Fi name (SSID).

WIFI SETTINGS

Wifi password

password

Wifi password (repeat)

password

Wifi name (SSID)

FLARM WIFI Link - 666

SAVE

7.3.1.3.10 FlarmLink Bluetooth setup

Bluetooth name can be changed here.

BLUETOOTH SETTINGS

Bluetooth name

FLARM BT link - 666

SAVE

7.3.1.3.11 FlarmLink database update

On that page user can load OGN database

7.3.1.3.12 FlarmLink sound settings

For each level of alarm, the user can set the type of the warning (quiet – no alarm, beeping or voice)
The initial volume can be set here.

If you press the TEST button, you can hear on audio output, what type of the warning is selected.

SOUND SETTINGS

Initial volume level

High Volume

New Traffic Alarm Type

Beep

Low Alarm Type

Short Voice

Important Alarm Type

Short Voice

Ugent Alarm Type

Short Voice

7.3.1.3.13 FlarmLink Button settings

In this menu a digital input/button function can be configured.

Button can be pressed short (click) or long (1sec). To each method can be applied one function.

Following functions are available:

- Volume change
- Mute/Unmute
- Pilots event
- Mute/Unmute for 5 minutes

Each action on the button is supported also with voice message. If you press "Volume change", You will hear "high volume", "medium volume", "low volume". For Mute/Unmute you will hear "mute" or "unmute",....

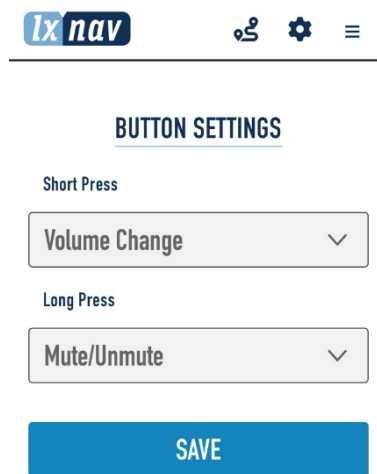

The screenshot shows the LXNAV application interface. At the top, there is a navigation bar with the LXNAV logo, a home icon, a settings gear icon, and a menu icon. Below the navigation bar, the title "BUTTON SETTINGS" is centered. Underneath, there are two sections: "Short Press" and "Long Press". The "Short Press" section has a dropdown menu currently set to "Volume Change". The "Long Press" section has a dropdown menu currently set to "Mute/Unmute". At the bottom of the settings area, there is a prominent blue "SAVE" button.

7.3.2 FlarmLink XCSOAR Connecting

FlarmLink provides two types of connections with the XCSOAR application: Bluetooth Low Energy (BLE) connections and TCP Client connections over Wi-Fi.

7.3.2.1 BLE connection

Step 1: In Config -> Devices, select device and click Edit. Click On Port and find your FlarmLink.

Step 2: As a Driver you can choose LXNAV or FLARM and press OK

Step 3: After successful connection you will see connected at FlarmLink device.



7.3.2.2 TCP Client connection

7.3.2.2.1 Connection with XCsoar

Step 1: In Config -> Devices, select device and click Edit. Click On Port and find TCP client.

Step 2: In IP address put: "192.168.1.1" and in TCP port select 2000. As a Driver you can chose LXNAV or FLARM and press OK

Step 3: After successful connection you will see connected at TCP client device.



7.3.2.2.2 Connection with SkyDemon

Press fly and choose AT-1

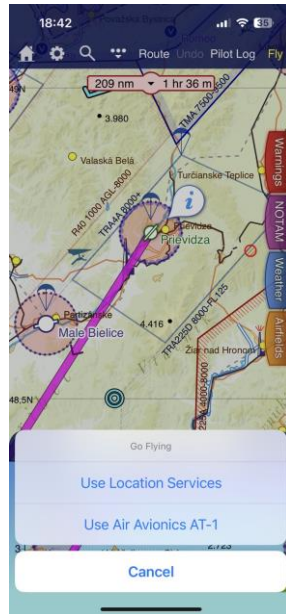

7.3.3 FlarmLink Wi-Fi factory reset

In case that you have forgotten the password or you don't know it, you can make a factory reset.

1. Press and hold the button.
2. Power on the device.
3. Wait until the Wi-Fi light starts blinking rapidly.
4. Release the button, then quickly press it again within 2 seconds (otherwise, the device will enter normal mode).
5. Hold the button until the Wi-Fi light stops blinking and stays solid – this indicates the FlarmLink has been factory reset.
6. Release the button to reboot the device.

7.3.4 Configuring PowerMouse settings with PowerFLARM config

PowerFlarm config is available at:

<https://gliding.lxnav.com/lxdownloads/software/>

PowerFLARMConfig v1.2.2

Declaration
Settings

PowerFLARMConfig

Select device: PowerMouse

PowerFLARMConfig Units

Distance unit: Kilometers
Altitude unit: Meters
Lat/Lon format: Decimal degrees (DD.dddd)

Basic settings

Recording interval: 4 s
ICAO 24-bit addr. (HEX): FFFFFFF
Aircraft type: 1 Glider / Motor glider
Airborne threshold: 2 m/s
Process Mode-C Targ.
Mode-C filtering method: Aggressive
Transponder type: No transponder
Use Mode-S baro. alt.
Beep on PCAS alarms
PCAS Antenna calib. val: 30

FLARM Range

Horizontal: 2 km
Vertical: 500 m

ADSB Range

Horizontal: Unlimited
Vertical: Unlimited

PCAS Range of transponder-only equipped targets

Horizontal: 7 km
Vertical: 610 m

Port 1

Baud: 19200 Baud
Messages: Navigation and FLARM
Protocol version: Default (e.g. for Gamin)

PCAS targets as PFLAU

Port 2

Baud: 19200 Baud
Messages: Navigation and FLARM
Protocol version: Default (e.g. for Gamin)

PCAS targets as PFLAU

Audio

Audio output
Audio volume: 100 %
Buzzer volume: 3

Miscellaneous

Brightness: 100 %
Battery type: Alkaline

PowerFLARMConfig is updated to version 1.2.2

Clear Load file Save Exit

Here you can set all settings for your PowerMouse device. File will be saved as flarmcfg.txt file, which you should save on the USD memory stick. To load this file into PowerMouse, insert USB key into USB slot on PowerMouse and switch on PowerMouse. File will be automatically loaded into device.



For Bluetooth to operate properly, baud rate of the port (port 1) must be set to 19200bps. If you changed baud rate for any other purpose (ex. updating) make sure to set it back to 19200bps if you want to use Bluetooth on that port.

7.3.5 PowerMouse configuration by using Flarm configuration tool

PowerMouse can be configured by Flarm Tool software which can be found here:
<https://flarm.com/support/tools-software/flarm-configuration-tool/>



In Farm tool are not supported all features, that can be configured for PowerMouse.

Q Search ... ABOUT US JOBS LOG IN ENGLISH

FLARM PRODUCTS SOLUTIONS TECHNOLOGY BUY NEWSROOM SUPPORT

HOME - SUPPORT - TOOLS & SOFTWARE - FLARM CONFIGURATION TOOL

FLARM CONFIGURATION TOOL

When installing FLARM in an aircraft, and before using a portable FLARM, it is very important that it is configured correctly. Use the configuration tool below to configure your device. After selecting the desired options, the configuration file is instantly downloaded.

Note that the configuration tool only works with the latest released firmware version. Before configuring the device, you need to update to the latest firmware version, independently of when you did the last firmware update.

We take the privacy of your data seriously and you can find our Privacy policy [here](#).

My devices
Log in to see your devices

New device
 Manufacturer: LXNAV
 Device: PowerMouse

START CONFIGURATION

BLOG

- 2019-01-31 New 2019 Obstacle Data Available [MORE](#)
- 2019-01-07 Fully-automated long-range UAV flights [MORE](#)

Obstacles 2019

The updated Obstacle databases for 2019 are now available in our [shop](#).

Create Config file:

- Select "New device" and choose "LXNAV" and "PowerMouse"
- Click on the button: Start configuration

Edit configuration file:

- After pressing button described above multiple options will show.
- Configure and adjust them to your liking
- More settings are available by checking "Show advance settings"

Show advanced settings

ICAO 24-bit aircraft address, hexadecimal

Official 24-bit ICAO aircraft address in hexadecimal notation, as issued by local CAA. It consists of six hexadecimal characters (0-9, a-f) and can be obtained from the aircraft papers. Must match the address configured in the Mode-S transponder. If the aircraft does not have a Mode-S transponder, it's possible to leave the field empty to use the device specific radio id. Enter "0" (zero) for random id (not recommended, will make Search and Rescue (SAR) very difficult).

Aircraft type

The configured aircraft type will influence motion prediction and collision risk algorithms and warnings for both the own aircraft as well as other aircraft. Ensure that you select the correct type.

Data sentences on data port 1

According to instructions from the display/equipment manufacturer.

Protocol version for data port 1

"Version 4" is typically supported by all displays. Select a higher version if the display supports it to have access to all functions. Select "Version 3" if Data sentences is configured as Garmin TIS.

Baud rate for data port 1

Baud rate (bit rate). Must match setting in attached display/equipment. Select at least 19200 for advanced functions.

Protocol version for data port 2

Protocol to be used. "Version 4" is typically supported by all displays. Select a higher version if the display supports it to have access to all functions.

Baud rate for data port 2

Baud rate (bit rate). Must match setting in attached display/equipment. Select at least 19200 for advanced functions.

Transponder type

Type of transponder that is installed in the aircraft.

CREATE CONFIG FILE

Edit advance settings:

- Do this the same way as described above for standard settings

Logging interval (seconds)
Applicable for IGC flight recording.
4 (Default) ▼

Remove all IGC files?
Deletes all IGC files from the device. Restarts the device.
 Yes
 No (Default)

Remove obstacle database?
Deletes the obstacle database (if installed) from the device. Restarts the device.
 Yes
 No (Default)

Pilot name
Applicable for IGC flight recording.

Co-pilot name
Applicable for IGC flight recording.

Glider ID
Applicable for IGC flight recording.

Glider type
Applicable for IGC flight recording.

Competition class of glider
Applicable for IGC flight recording.

Competition ID
Applicable for IGC flight recording.

Stealth mode
Hides tactically relevant flight data for usage at competitions. Receiving stations may use the received data for the purposes of traffic safety only or with a time delay of 10 minutes. Tactical data like climb rate are omitted or randomized.
 Enable
 Disable (Default)

No-Track mode
Enhanced privacy mode. Receiving stations may use the received data for the purposes of traffic safety only. If enabled, Search and Rescue (SAR) based on data received by ground stations is not possible.
 Enable
 Disable (Default)

Create config file:

- Click button "Create config file"
- File (FLARMCFG.txt) will automatically be downloaded to your computer

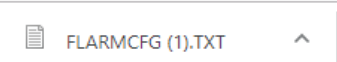

To load this file into PowerMouse, save it on the USD memory stick. To load this file into PowerMouse, insert USB key into USB slot on PowerMouse and switch on PowerMouse. File will be automatically loaded into device.

7.4 OGN registration

Flarm can be registered to Open Glider Network (OGN). For registration, you will need Flarm ID number. It is 6 digit hexadecimal code. It can be found on several places.

- IGC file
- Flarm config file (flarmcfg.txt)

For OGN registration, please visit following web site:

<http://wiki.glidernet.org/ddb>

After successful registration, your flarm device will be visible on several OGN portals.

<https://live.glidernet.org/>

<https://glidertracker.de/>

7.4.1 IGC file

If you open IGC file with notepad, you must search for ID as follows

```
AXFL8AQ
HFDTEDATE:161220
HFDTE161220
HFFXA500
HFPLTPILOTINCHARGE:undefined
HFCM2CREW2:undefined
HFGTYGLIDERTYPE:undefined
HFGIDGLIDERID:undefined
HFDTMGPSDATUM:WGS84
HFCLCOMPETITIONCLASS:undefined
HFCIDCOMPETITIONID:undefined
HFRWFIRMWAREVERSION:FLARM, 6. 67
HFRHWHardwareVERSION:1.0
HFFTYFRTYPE:PowerFLARM
HFGPSRECEIVER:u-blox 8, 56ch, 50000m
HFPRSRESSALTSSENSOR:MEAS MS5607, 25000m
I023638FXA3940SIU
LFLA06024907FRW 6. 67
LFLA060249 STEALTH OFF
LFLA060249 NOTRACK OFF
LFLA060249ID 2 D01580
LFLA060249OB
LFLA06024907OBSTEXP
LFLA06024907DEVNO FLANGA10W-005504
LFLA06024907BUILD a072808ac
LFLA06024907RANGE 65535
LFLA06024907ACFT 8
LFLA06024907THRE 2
LFLA06024907FREQ 100
LFLA06024907CFLAGS 00
```

7.4.2 Flarm CFG file

If you plug into PowerMouse empty USB memory stick, a NGAxxxxx.TXT file will be copied on it, and where xxxxx is internal serial of FLARM module. If you open the file, you will find Flarm ID at the bottom as follows:

```
.
.
.
00078.362 INFO CONFIG cap = DP2;USBH;BARO;IGC
00078.366 INFO CONFIG region = ALL
00078.367 INFO CONFIG build = f746001a7
00078.368 INFO CONFIG deviceid = FLANGA10W-004100
00078.368 INFO CONFIG radioid = D01580
00078.369 INFO CONFIG idType = 2
00078.382 INFO PFAPP Starting PowerFLARM application
00078.382 INFO PFAPP Cleaning up FFS...
00078.472 INFO PFAPP Initializing command parser and RPC server on Data Port #1
00078.476 INFO PFAPP Initializing command parser and RPC server on Data Port #2
```

7.5 Saving flight on the USB stick

The last 20 flights will be downloaded at every switching on (only if the USB stick is inserted). If there are already some of the 20 flights on the USB stick, they will not be downloaded again. That means: if you have been flying a lot without downloading flights, the download procedure will take some time, so don't switch off. To download one flight after landing perform the following procedure: Wait a 3 minute after landing. Then switch off power for at least 5 sec. Insert the USB stick (in case it's not already inside) and switch on again.



The collision avoidance functionality does not depend on the status of the USB stick (inserted or not)

7.6 Updating the obstacle database

The firmware update will be executed, when the system finds a file with the extension ***.obs.** on the USB stick root. The procedure runs identically to the firmware update and takes a few minutes. Please delete the obstacle file from the USB stick after the update.

All data must be in the USB stick root directory. Folders and subfolder are not allowed. Names of the files shall not be changed.



Loading new obstacle database will overwrite the old obstacle database



File format FAT16 or FAT32 and USB 2.0 type is supported.



FLARM Tools is used only for Classic FLARM and in not compatible with PowerMouse.

Obstacle database can be purchased on official Flarm web site www.flarm.com, section products/obstacles.

Under manufacturer, please select LXNAV
For device, please select PowerMouse.

New device

Manufacturer:

Device:

Click here to access the device manual with instructions on how to find the internal FLARM serial number. The serial number has the form FLANGA10W-001234. Do not use the serial number of the PowerMouse.

(Internal) FLARM Serial Number:

Internal serial number is available in IGC file. You will find it in following format:

LFLA14313607DEVNO FLANGA10W-**002445**

If you open IGC file with notepad, please search for text "FLANGA10W". If you open IGC file with SeeYou, please right click and select flight properties, then Misc, scroll down for approximately one page and you will find the internal serial number.

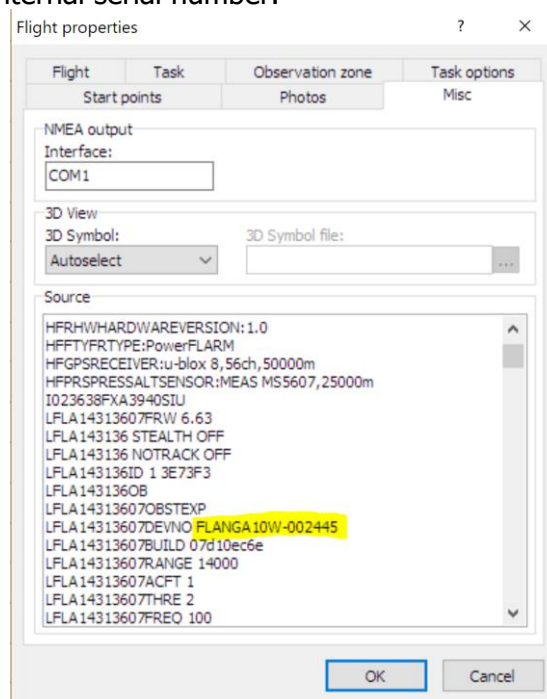

All PowerMouses logging IGC logs, even they don't have IGC option. PowerMouses without IGC option will have IGC flight without signature and will be not valid for badges or OLC.

7.7 Declaring tasks

Flarmcfg.txt files can also contain task declaration.

You can declare the task on PowerMouse in three possible ways:

- If connected to S8x/10x vario from the vario
- If connected to LX80xx/90xx system from the unit
- Via USB stick

In order to declare task via USB stick you will need PowerFlarmConfig software already mentioned in previous chapters.

To declare task, go under "Declaration" and define pilots and airplanes parameters. By pressing "Load" button you upload the .cup waypoint file from which you can then select points for flight declaration. After you are done editing you save and transfer the file to the device the same way as described in chapter 6.2.1.

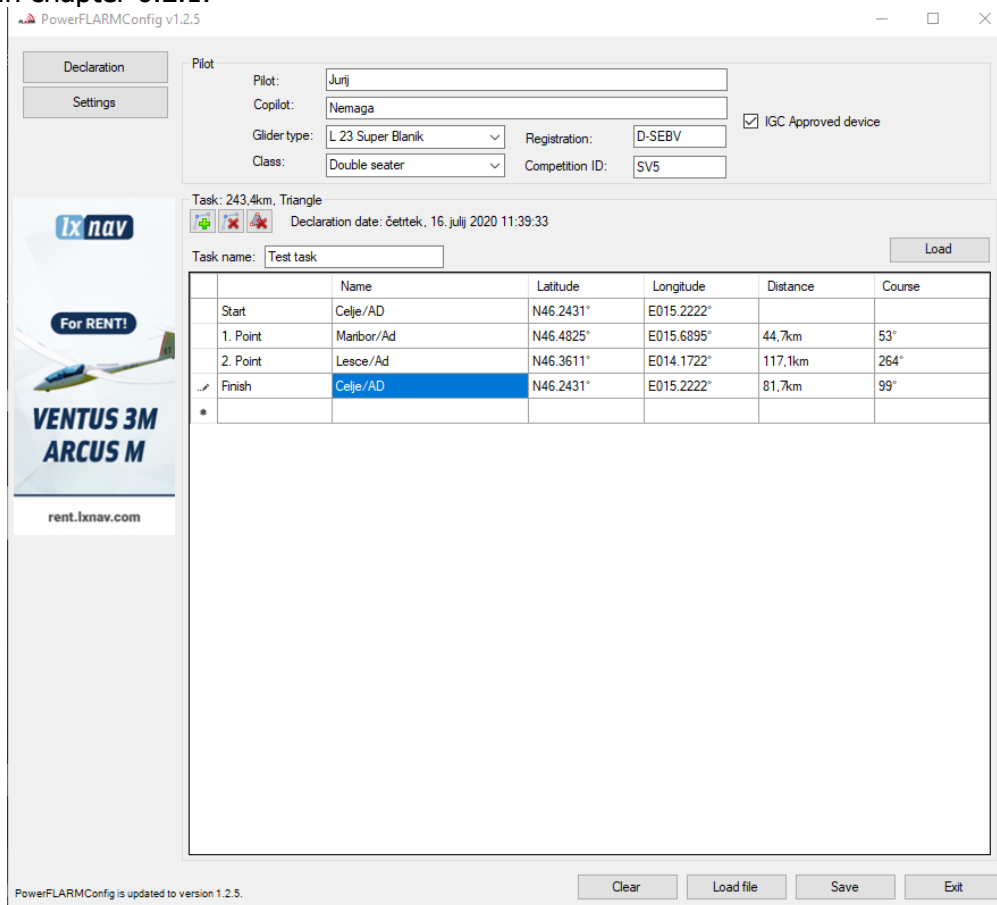

8 Error codes

- 11 = Firmware expired (requires valid GPS information, i.e. will not be available in the first minute or so after power-on)
- 12 = Firmware update error
- 21 = Power (e.g. voltage < 8V)
- 22 = UI error
- 23 = Audio error
- 24 = ADC error
- 25 = SD card error
- 26 = USB error
- 27 = LED error
- 28 = EEPROM error
- 29 = General hardware error
- 2A = Transponder receiver Mode-C/S/ADS-B unserviceable
- 2B = EEPROM error
- 2C = GPIO error
- 31 = GPS communication
- 32 = Configuration of GPS module
- 33 = GPS antenna
- 41 = RF communication
- 42 = Another FLARM device with the same Radio ID is being received. Alarms are suppressed for the applicable device.
- 43 = Wrong ICAO 24-bit address or radio ID
- 51 = Communication
- 61 = Flash memory
- 71 = Pressure sensor
- 81 = Obstacle database (e.g. incorrect file type)
- 82 = Obstacle database expired.
- 91 = Flight recorder
- 93 = Engine-noise recording not possible
- A1 = Configuration error, e.g. while reading flarmcfg.txt from SD/USB.
- B1 = Invalid obstacle database license (e.g. wrong serial number)
- B2 = Invalid IGC feature license
- B3 = Invalid AUD feature license
- B4 = Invalid ENL feature license
- B5 = Invalid RFB feature license
- B6 = Invalid TIS feature license
- 100 = Generic error
- 101 = Flash File System error
- 110 = Failure updating firmware of external display
- 120 = Device is operated outside designated region. The device does not work.
- F1 = Other

9 PowerMouse/PowerMouse+ Mount

To firmly secure PowerMouse it is recommended to use PowerMouse Mount. Mount designed by LXNAV allows easy installation and quick removal of the PowerMouse device while providing a strong grip and makes it impossible for device to move while in flight.

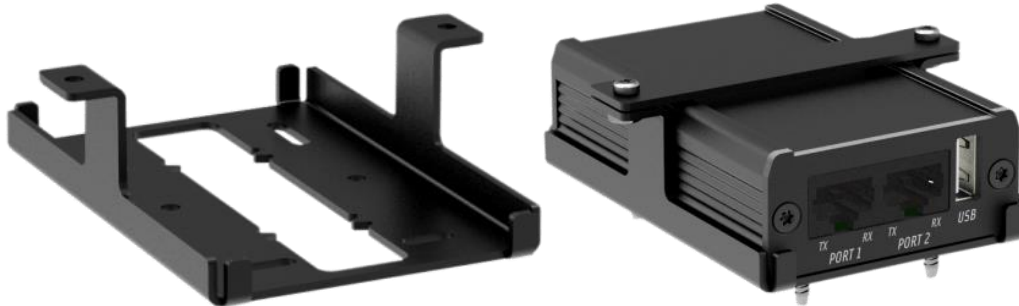

When installing PowerMouse mount first firmly mount the bottom part (left) with screws that came with the product. Then place PowerMouse into the mount and place the top bar over it as seen on picture above (right). Secure it with two screws.



PowerMouse Mount does not come packaged with PowerMouse and must be purchased separately.