

## INSTALLATION

The airspeed switch, or differential pressure switch, is to be installed behind the instrument panel. The switch is to be spliced in line with the aircraft pitot and static lines. The switch is to be secured in place to an adjacent wire harness or structure with cable ties.

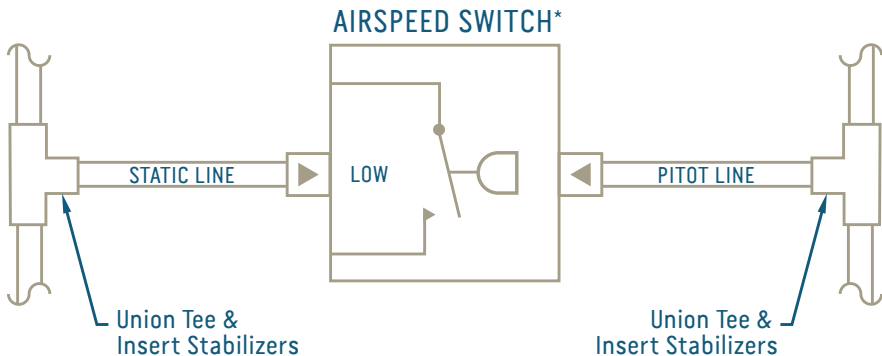

\* Low when airborne,  $34 \pm 3$  knots